

# SW405K5

## PRODUCT SPECIFICATIONS

# SANY



## STANDARD FEATURES

- Engine: Deutz TCD 7.8 (EU Stage 5)
- Boom Suspension System
- Locking Differential Axle
- Automatic Transmission Kick Down
- Bucket Self-Leveling and Return to Dig
- SANYLive Telematics
- Single Joystick Control
- Third Function Hydraulics
- Reversible fan
- 360° View Camera

Gross Power  
**195 kW**

Bucket Capacity  
**3.2 m<sup>3</sup>**

Operating Weight  
**18 500 kg**

Straight Turn Tipping Load  
**14500 kg**

Full Turn Tipping Load  
**13100 kg**

# PRODUCT SPECIFICATIONS

# SANY SW405K5

## Machine Parameters

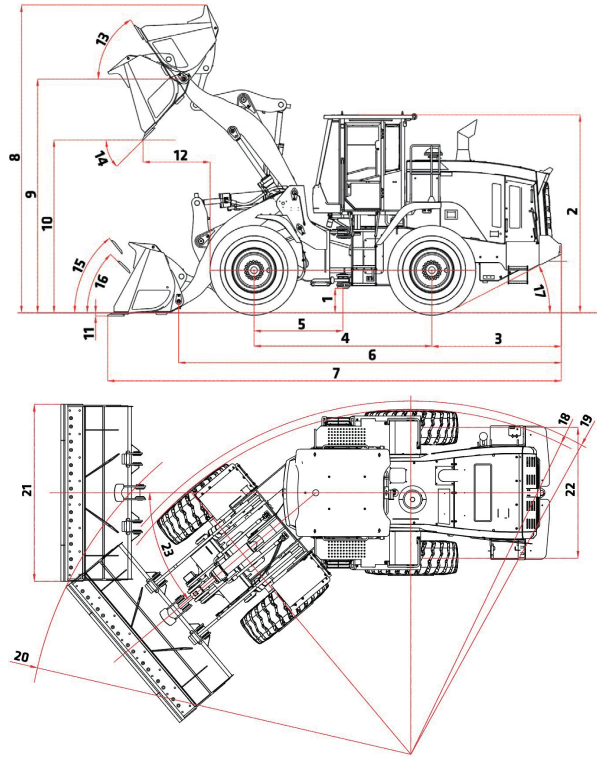

### OVERALL DIMENSIONS

	STANDARD
1 Ground clearance	430 mm
2 Height to Top of Cab	3 580 mm
3 Center Line of Rear Axle to Edge of Counterweight	2 335 mm
4 Wheelbase	3 200 mm
5 Center Line of Front Axle to Center Pivot	1 600 mm
6 Shipping Length without Attachment	7 040 mm
7 Shipping Length with Bucket	8 180 mm
8 Max. Dump Height	5 415 mm
9 Hinge Pin Height at Max. Lift	4 145 mm
10 Dump Clearance at Max. Lift	3 100 mm
11 Dig Depth, Level Bucket	30 mm
12 Reach at Max. Lift and 45° Discharge	1 185 mm
13 Roll Back at Max. Lift	58°
14 Dump Angle at Max. Lift and Dump	45°
15 Roll Back at Carry Height	50°
16 Roll Back at Ground	45°
17 Tail Angle to the Rear Wheel	27°
18 Clearance Circle to Outside of Tires	5 635 mm
19 Clearance Circle to Counterweight	5 911 mm
20 Max. Circle	6 465 mm
21 Width of the Bucket	3 015 mm
22 Width	2 200 mm
23 Articulation Angle	+/- 40°

In the interest of continual equipment development, SANY reserves the right to change these specifications at any time without prior notification.

#### WEIGHT

Operating Weight	18 500 kg
------------------	-----------

#### ENGINE

	Deutz TCD7.8
Max Gross Power	195 kW
Rated power	170 kW
Max Gross Torque	1308 Nm
Displacement	7.8 L

#### OPERATING

Bucket Capacity	3.2 m <sup>3</sup>
Breakout Force	180 kN
Tipping Load Straight	14 500 kg
Tipping Load @ Full Turn	13 100 kg
Clearance (full lift 45° dump)	3100 mm
Reach (full lift 45° dump)	1185 mm

#### HYDRAULIC SYSTEM

Max Flow	306.6 LPM
Max Pressure	28 MPa

#### HYDRAULIC CYCLE TIMES

Raise	5.4 sec
Dump	1.9 sec
Float Down	3.3 sec
Total Cycle Time	10.6 sec

#### SERVICE CAPACITIES

Fuel Tank	300 L
Cooling System	43 L
Engine Crankcase	23 L
Transmission	35 L
Front Axle	28 L
Rear Axle	28 L
Hydraulic Tank	290 L
DEF Tank	20 L

#### TRANSMISSION

Shift Modes	Automatic, Manual, Kick Down
Forward Gear 1-4	7.3/13.5/26/40 km/h
Reverse Gear 1-3	7.3/13.5/26 km/h

#### POWER TRAIN

Front Axle	Fixed
Traction Aid	Manual Differential Lock
Rear Axle	Oscillating
Traction Aid	Open Differential
Service Brake	Wet Disk
Parking Brake	Disk Brake

# SANY

# PRODUCT EQUIPMENT

Standard ● Optional ○

## ENGINE

Exhaust aftertreatment (DPF+SCR)	●
Keyless start	●
Engine emergency stop (in cab)	●
P/E Patten	●
Cold start aid (air pre-heated)	●
Hydraulic-driven fan, regulated by temperature (Reversible rotation, manual)	●

## POWER TRAIN

Gear selector lever (Steering-column)	●
Fully automatic shifting 1-4, H/L Patten & Manual	●
Automatic Transmission Kick Down	●
Clutch-cutoff	●
Service brake, 4-wheel, wet-type, hydraulic brake	●
Parking brake, Electronically controlled, hydraulic caliper disc brake	●
Differential lock front axle (manual)	●

## HYDRAULIC

Full variable load-sensing system with steering priority	●
Single-lever joystick with F/R+KD+horn+3rd function valve roller)	●
Secondary steering	●
Dual brake pedals	●
3rd function valve	●
Hydraulic quick coupler lines	●
Ride control system(Boom suspension system)	●
Boom kick-out	●
Bucket self-leveling and return to dig	●

## WORK TOOLS

Bucket volume 3.2m <sup>3</sup> (Cutting edge, bolt-on)	○
Quick coupler	○

## CABIN

Cab with ROPS / FOPS certification	●
Steering wheel with turning signal control lever	●
Emergency hammer	●
Rear window, heated	●
Rear mirrors, outside (2, foldable, heated) ,inside(1)	●
Sun visor, front window	●
Air-Suspension seat (cloth, heated)	●
Seat belt, 2-point retractable	●
Armrest adjustable in multiple directions	●
Rear-view camera	●
360° view camera	●
7 inch smart color display	●
Auto air conditioner	●

## ELECTRICITY

Battery main switch	●
12-volt socket	●
Cigarette lighter, 24V	●
USB socket	●
Bluetooth radio	●
Back up alarm	●
Travel acoustic alarm	●
Travel strobe light alarm	●

\*Standard and optional equipment may vary. Consult your local dealer for details\*

# SANY



**QUALITY CHANGES THE WORLD**

**SANY ITALIA S.R.L.**

**VIA DRUENTO 254/B VENARIA REALE (TO) - ITALY**

**TEL. 0118002130**

**[HTTPS://WWW.SANYITALIA.COM](https://www.sanyitalia.com)**

October 2022 Edition

Materials and specifications are subject to change without notice. Featured machines in photos may include additional equipment. See your local dealer for available options please.